

Guitar amplifier

Written by Menno de Graaf

Friday, 18 June 2010 16:09 - Last Updated Monday, 10 December 2012 21:44

Products related to this project are for sale on [this page](#). **Introduction**

The aim of this project is to build a modular guitar or bass amplifier. You can decide yourself how many channels you want to incorporate, all with their own gain and tone controls pots a effect loop and line out connections.

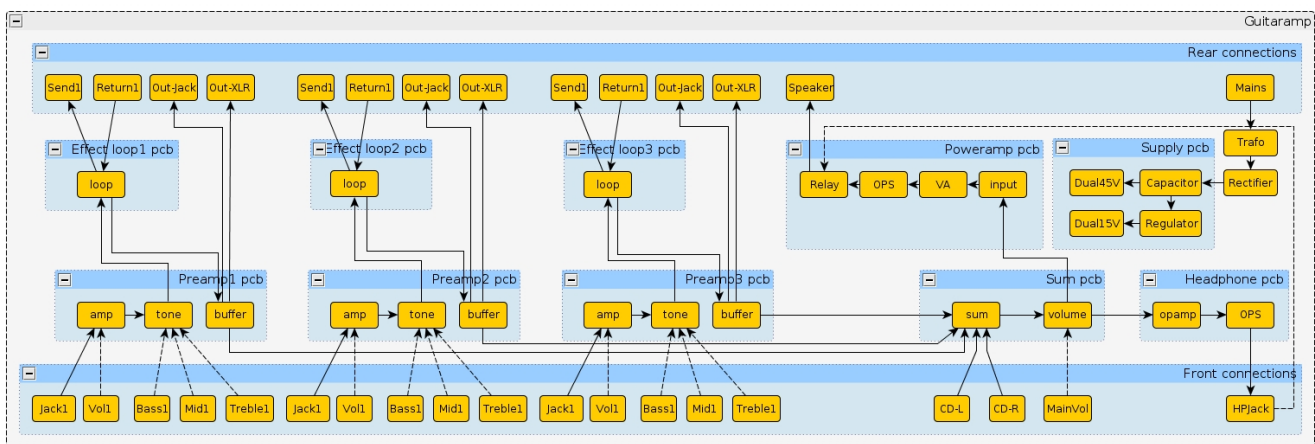

PCB's Supply

The supply pcb contains the electrolytic capacitors for rectification and has a dual supply for the power amplifier (voltage depending on the used transformer, 45V in this case) and a regulated dual 15V supply for the various opamps. It is equipped with lots of supply connectors for the other pcb's.

Preamp

The preamp pcb contains a 6.35mm input jack and 4 potmeters, 1 for gain, 3 for tone controls (bass, mid, treble). Amplification is done in three opamp stages (IC1a+b & IC2a) where the gain

Guitar amplifier

Written by Menno de Graaf

Friday, 18 June 2010 16:09 - Last Updated Monday, 10 December 2012 21:44

is determined by R20, R9 and R14 (with current values maximum gain of 28dB). Depending on the setting of the gain potmeter, anything from clean amplification to heavy distortion can be achieved. The opamp input of IC1a is protected using D3 & D4. If needed, a supply voltage for an active guitar/bass element is available on the input jack by using a stereo cable and the 'power' switch. Using the 'presence' switch some extra amplification around 10kHz can be chosen, which is a "treble boost" function used in many amplifiers.

The tone controls are incorporated in the feedback loop of opamp IC2b. With the potmeters the bass (25Hz), mid (550Hz) and treble (10kHz) regions can be adjusted between -15dB and +15dB. An effect loop can be connected to the Send/Return connectors.

The return signal from the effect loop is buffered using opamp IC3a to be available for an inverted (cold) XLR output (inversion was caused by the tone controls). IC3b inverts the signal again to be connected to the normal (hot) XLR output, Jack output and output to the Sum pcb.

The components T1, T2, R21 and R24, give a supply of nearly 15V on the middle connection of the input jack. The components limit current to 13mA, which allows the jack connection to be safely shorted to ground, without damage. Using R10, LED1 switches off if current limiting is applied (or the power switch is off). The supply provision has a number of useful applications: it can be used to power active guitar electronics, so no battery is needed anymore. Another very useful application is an impedance converter, which is a small (fet) circuit that can be mounted in the jack plug that goes into your guitar. It makes sure your amp is driven from a low impedance source, so less noise is picked up and cable length does not influence guitar sound anymore. Also it gives a tube-like distortion. More on that later.

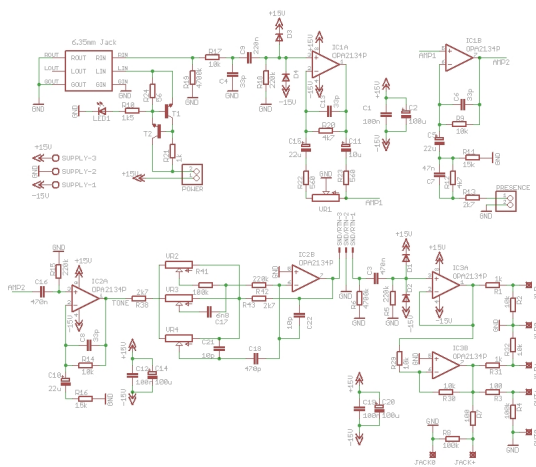

Guitar amplifier

Written by Menno de Graaf

Friday, 18 June 2010 16:09 - Last Updated Monday, 10 December 2012 21:44

Effect loop

The effect loop pcb contains 2 jack connectors, for send and return to external effects. If needed an extra master potmeter can be used in this loop to adjust the output level of every single preamp. Another option is an active effect, e.g. a compressor, or a passive effect, e.g. a soft clipping circuit with diodes or leds.

Sum & headphones

The sum & headphones pcb adds the signals from a maximum of five preamps in opamp stage IC1A, additionally it has cinch connections for connecting an external cd-player or mp3-player. Potmeter R12 sets the output volume to the power amplifier. If needed, an external mixed jack output is provided. After the volume adjustment, the signal enters a small headphone amp circuit. Opamp IC1B is used in combination with a push-pull bipolar output transistors set to get more current drive. When a headphone is connected, the output of the poweramp can be disconnected from the speaker using the MUTE signal, so only sound from the headphones can be heard.

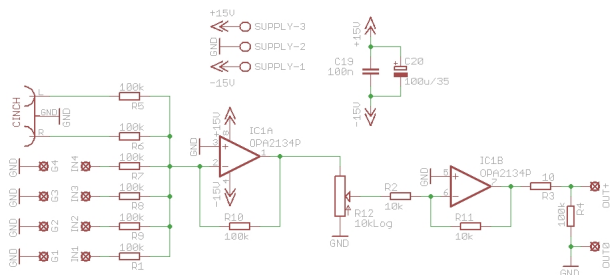

Guitar amplifier

Written by Menno de Graaf

Friday, 18 June 2010 16:09 - Last Updated Monday, 10 December 2012 21:44

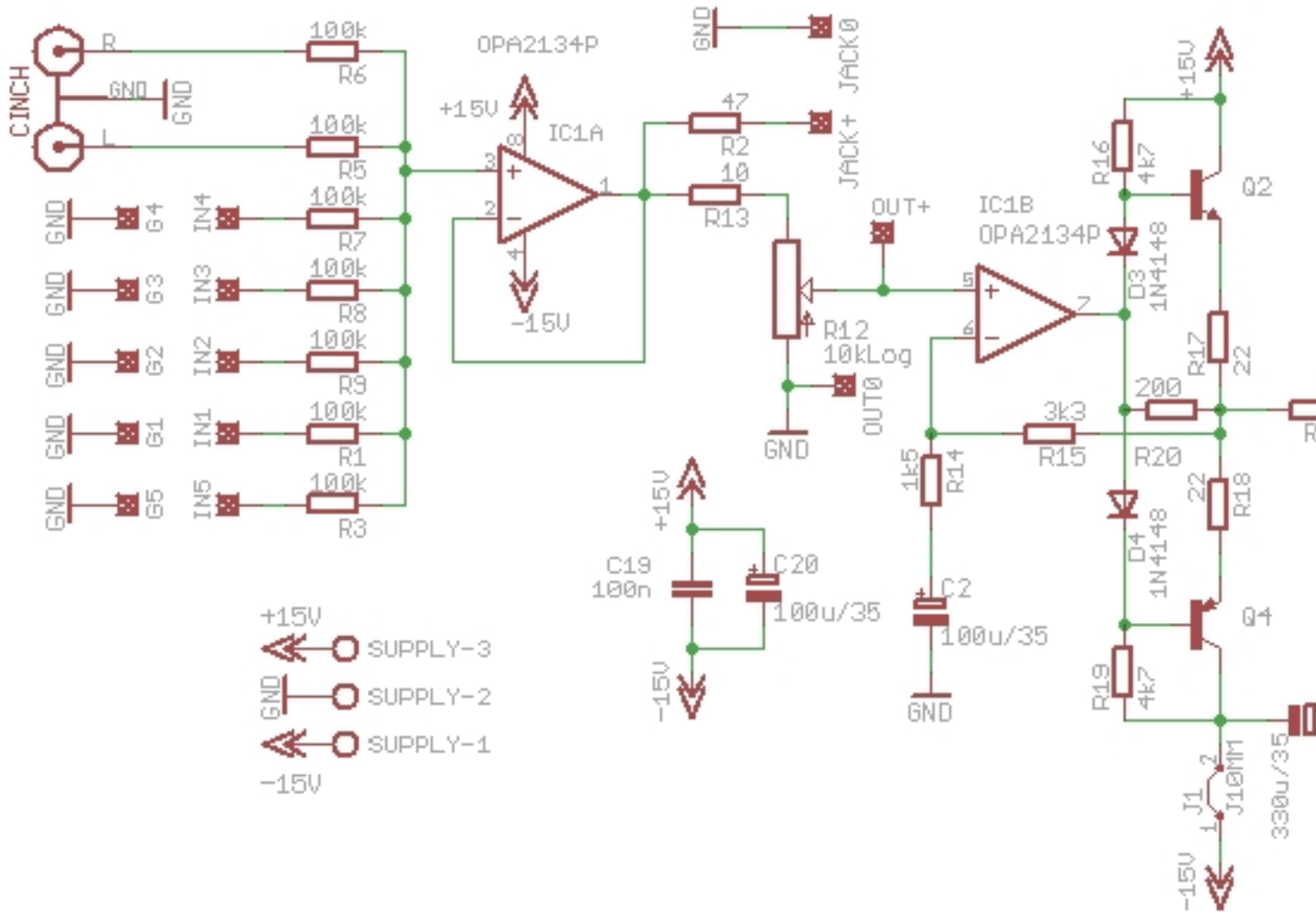

Poweramp

The poweramp amplifies the signal at line level to be connected to the output speaker or speaker cabinet. The same pcb as used in the [mosfet poweramp project](#) is used.

Prototype

A prototype is currently being built. Some photo's are shown next:

Guitar amplifier

Written by Menno de Graaf

Friday, 18 June 2010 16:09 - Last Updated Monday, 10 December 2012 21:44

