

PIC-based Speaker Protection

Geschreven door Menno de Graaf

donderdag, 24 maart 2011 10:32 - Laatst aangepast maandag, 22 augustus 2016 20:41

There are no translations available.

Products related to this project are for sale on [this page](#).

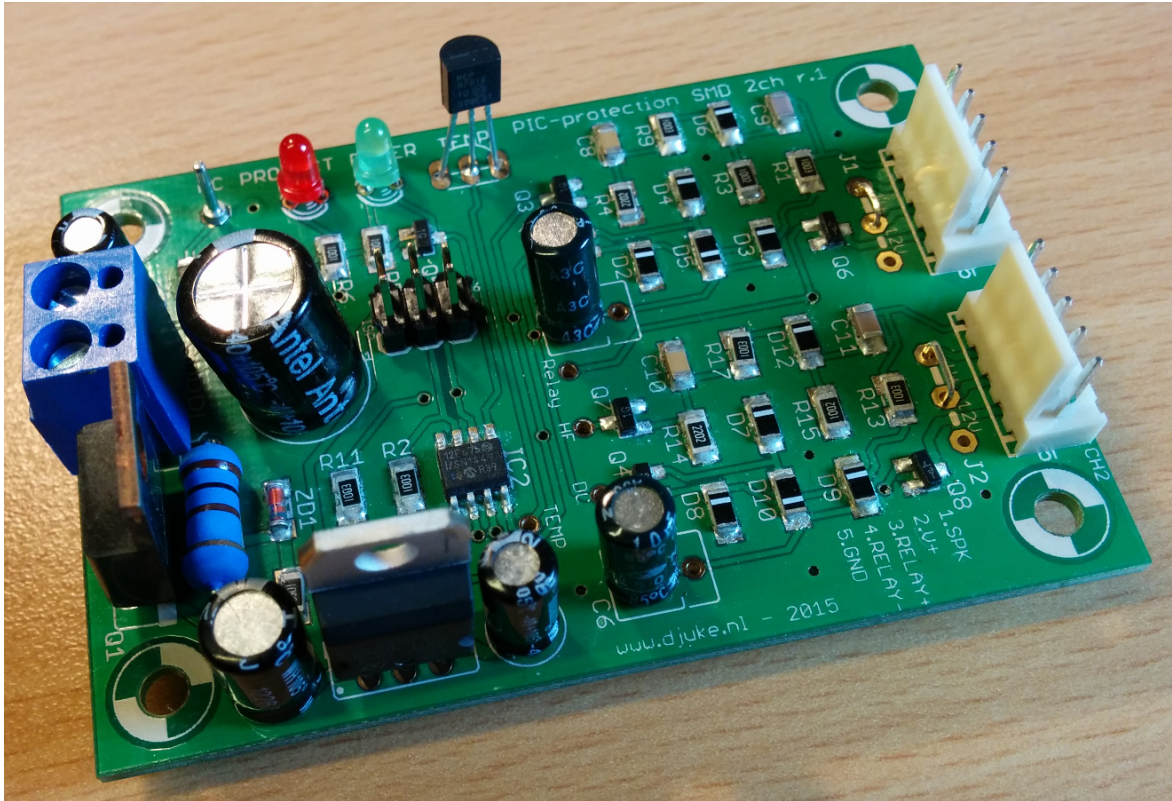

PIC-based Speaker Protection

Geschreven door Menno de Graaf

donderdag, 24 maart 2011 10:32 - Laatst aangepast maandag, 22 augustus 2016 20:41

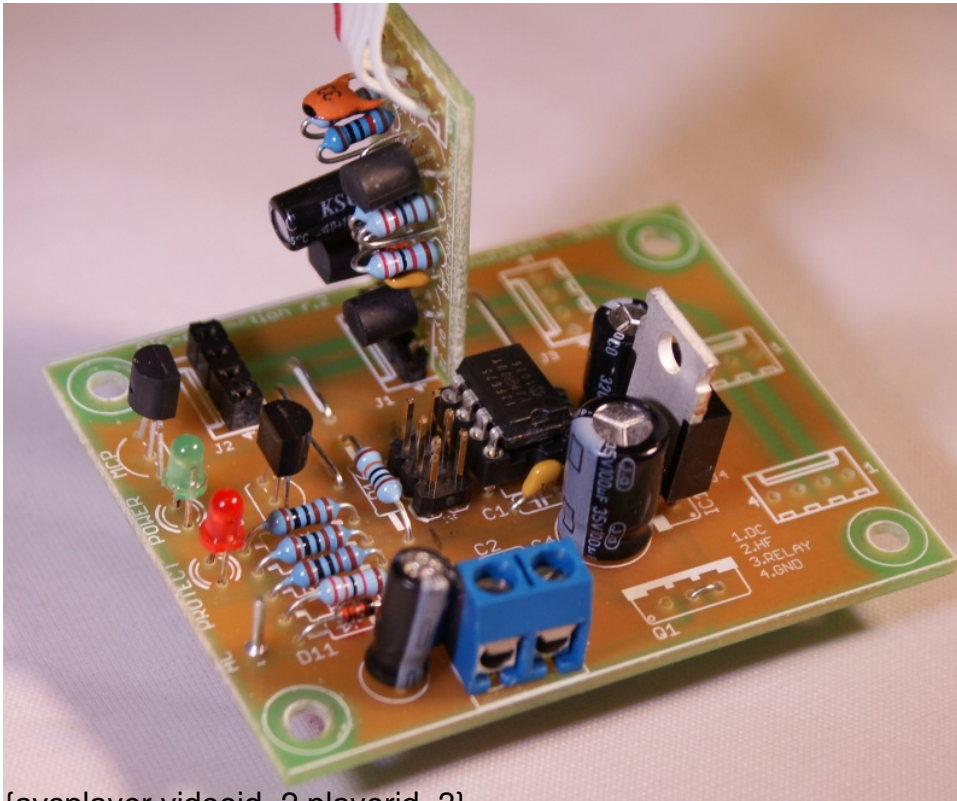

{avsplyer videojd=2 playerid=3}

Introduction

This modular speaker protection project helps to protect your precious loudspeakers in case of a malfunction of a power amplifier. It features protection against DC voltage, high-frequency instability and over-temperature. The output relay (or output stage rail supply) is switched on with a delay of a few seconds to avoid the nasty sound when you switch on the amplifier. When the amplifier is switched off, loss of AC is detected and the output relay disconnects the amplifier (or supply) from the speakers. A power LED and protect LED can be connected to the amplifier front panel to provide visual feedback. By using small detector pcb's that can be mounted sideways to the main pcb up to 5 channels can be protected.

Schematic

Main pcb

The heart of this PCB is a PIC12F675 microcontroller with the functionality implemented in a small piece of software. The top left part delivers a 5V supply for the microcontroller, and can be fed directly from the positive rail supply (max 60VDC for the MJE3055). In that case R7, D1, C2 and Q1 form a cascode to reduce the voltage to about 12V. If a lower voltage supply (e.g. 15V) is available, these components can be omitted and the connection for Q1 bridged. The AC detection circuit of D11, R8, C5, R10 and Q5 is used to directly switch the output LED using R5, which is connected to GP2 (digital input). The protect LED is connected to output GP5 using R6. An optional MCP9701 temperature sensor measures the temperature inside the amplifier

PIC-based Speaker Protection

Geschreven door Menno de Graaf

donderdag, 24 maart 2011 10:32 - Laatst aangepast maandag, 22 augustus 2016 20:41

normal musical content but will hopefully protect your speakers and/or output zobel network in the power amplifier in the case of a (speaker induced) instability occurs.

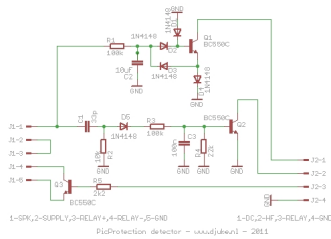

The relay can be mounted on or after the power amplifier board, or 2 relays can be used to switch the positive and negative supply of the output stage. One side of the relay inductor is connected to the positive rail supply, which is the connection between J1-2 and J1-3 (I normally use 48V relays, but you can adapt this to your own need). The other side of the relay is connected to J1-4 and through Q3 and J1-5 to the power amplifier ground. Transistor Q3 is switched by the microcontroller control voltage on J2-3. The use of BC550 limits the max relay supply voltage to 50VDC, if a higher voltage is needed, Q3 can be replaced with e.g. BC546.

Update: Combined SMD version for 2 channel protection

As it turns out, most people only need 2 channel protection for the left and right channel of a power amplifier. To make the circuit more compact and faster to build, I made a redesign with SMD components, which combines 2 channel protection on one pcb:

PIC-based Speaker Protection

Geschreven door Menno de Graaf

donderdag, 24 maart 2011 10:32 - Laatst aangepast maandag, 22 augustus 2016 20:41

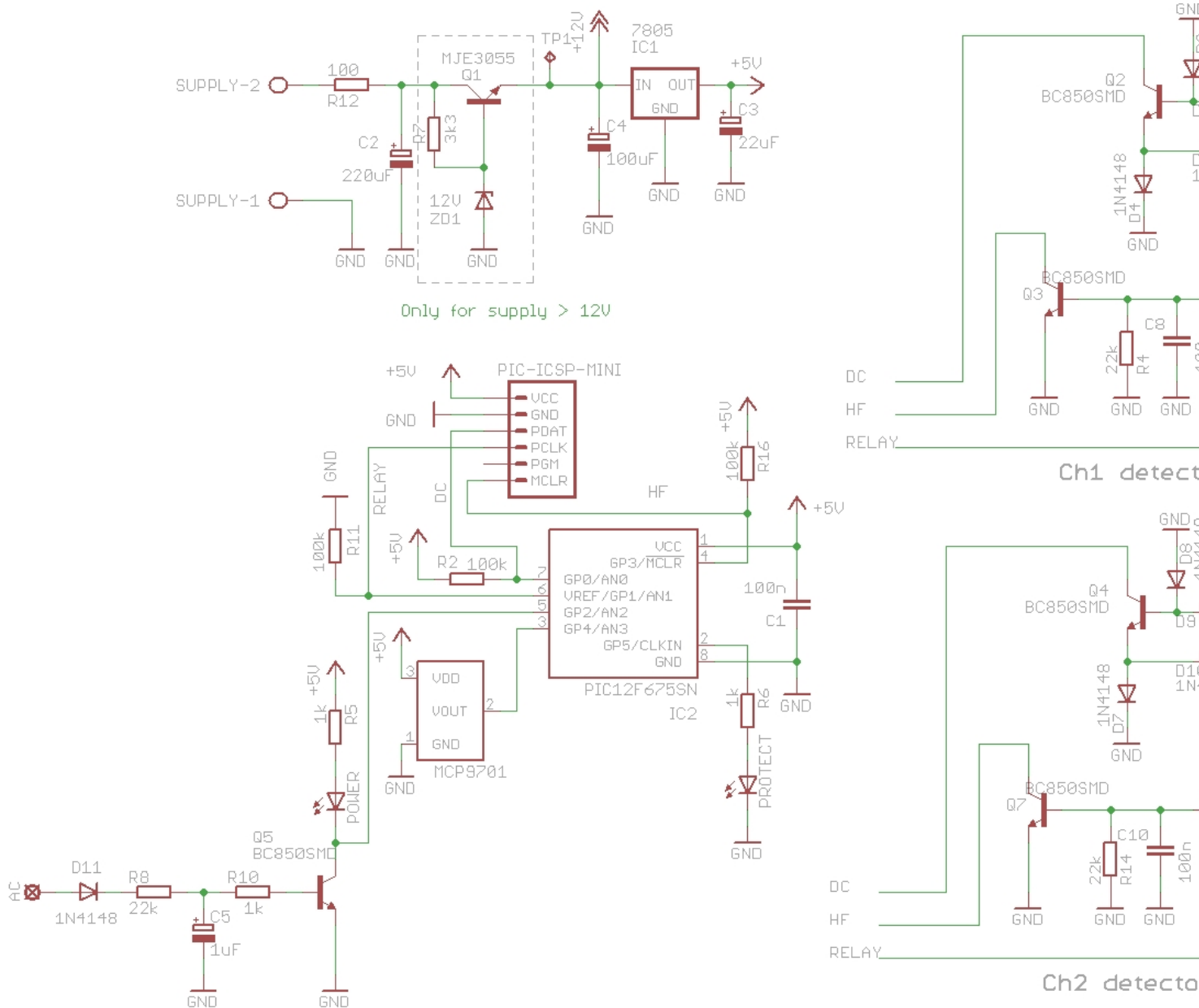

Software functionality

Most of the functionality of this project is implemented in software:

- If DC is detected (GP0 becomes 0), switch on protect LED, switch off output relay
- If HF is detected (GP3 becomes 0), blink protect LED at 4Hz, switch off output relay
- If temperature becomes more than 50 deg C (warning temp), blink protect LED at 1Hz, output relay stays on
- If temperature becomes more than 70 deg C (error temp), blink protect LED at 2Hz, switch off output relay
- If AC is first detected (GP2 becomes 1), switch on output relay after 3s, if above

PIC-based Speaker Protection

Geschreven door Menno de Graaf

donderdag, 24 maart 2011 10:32 - Laatst aangepast maandag, 22 augustus 2016 20:41

conditions are all ok. During delay, protect LED blinks at 0.5Hz.

- If AC is lost, immediately switch off output relay.
- Automatic recovery from a protect situation is only allowed for overtemperature. In the case of DC or HF protection, user interaction is needed, e.g. by switching the amplifier off and on.

Software for this project is written using SDCC, I am not willing to give it away, but a [programmed microcontroller is available](#)

Prototypes

Modular through-hole version

A prototype with one detector has been built, photo's are shown below. Note how you can easily stack the detector pcb on the main pcb using a female pinheader. The detector pcb can be stacked straight if you only need one or two channels, or sideways if you want to use all five channels.

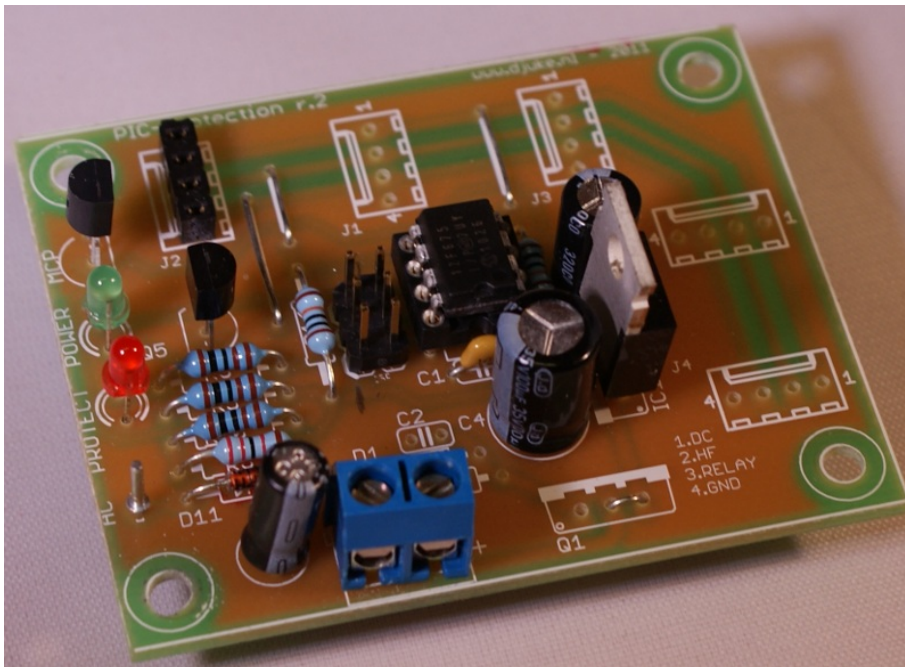

PIC-based Speaker Protection

Geschreven door Menno de Graaf

donderdag, 24 maart 2011 10:32 - Laatst aangepast maandag, 22 augustus 2016 20:41

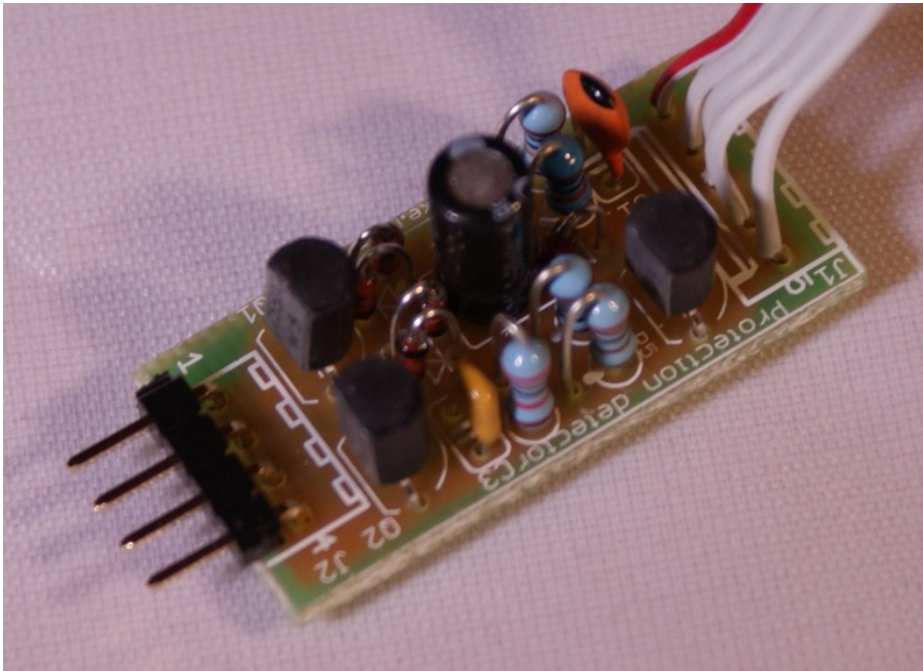

2-channel SMD version

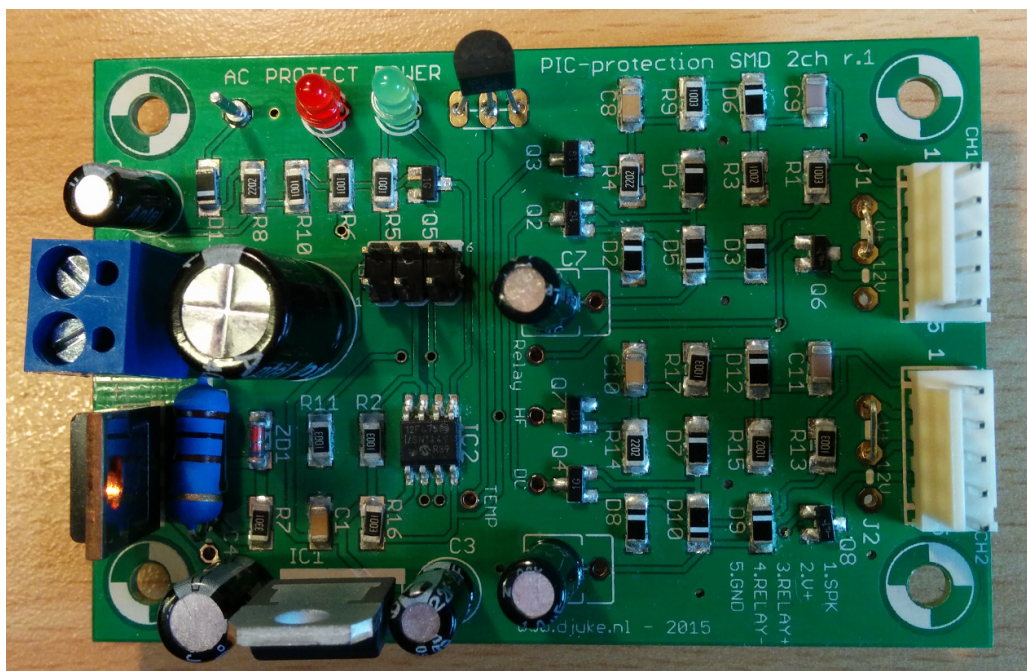

PIC-based Speaker Protection

Geschreven door Menno de Graaf

donderdag, 24 maart 2011 10:32 - Laatst aangepast maandag, 22 augustus 2016 20:41

